

UNIQUE FIRE INDUSTRY

PRODUCT CATALOGUE



ADDRESS

No. 9, Jalan Anggerik Mokara 31/55,
Kota Kemuning, Seksyen 31, 40460,
Shah Alam, Selangor, Malaysia

CONTACT

T: +603 5131 1226

E: contactus@uniquefire.com

W: www.uniquefire.com



SCAN ME



UNIQUE FIRE HOLDINGS MILESTONE

1997 - 2013

UNIQUE FIRE INDUSTRY

Assembled our own brand of fire hoses (2000).
Changed our name from UBE to Unique Fire Industry Sdn Bhd ("UFI") and registered the trademarks for Commander and Yama brands fire hoses (2003)



2016

UL APPROVAL

UFI obtained our first international approval, UL certification for our Unique227 brand of HFC fire suppression system

2018

SGP CERT

UFI obtained SGP for our HFC fire suppression systems - Unique227 brand from TNB.
UDI commenced business of distributing custom graphics designed fire extinguishers.

2021

FM APPROVAL

UFI received first FM approvals certification for our Unique227 and Unique5112 brand of fire suppression system.



NOW

ACE MARKET

As of 2022, we are proudly listed on the ACE Market of Bursa Malaysia.

FK-5-1-12 CLEAN AGENT

Unique Fire also offers FK-5-1-12 that has received the component recognition from Underwriters Laboratories (UL), and Factory Mutual (FM) that certify the technical specifications as required by NFPA 2001 in order to ensure the effective of clean agents in suppressing fires. Other fire extinguishing agents are available upon request.

Unique 5112 is a trademark of Unique's FK-5-1-12, Dodecafluoro-2-methylpentan-3-one. FK-5-1-12m-my2 is another widely used extinguishing clean agent. It is environmentally safe and best used in fire hazard areas containing A, B, & C classes of fire. It has been approved by US EPA and ISO for its safe characteristic and fire extinguishing effectiveness.

Clean Agents offered by Unique Fire is guaranteed to meet the minimum NFPA 2001

SCAN ME



DESCRIPTION

Unique Fire also offers FK-5-1-12 that has received the component recognition from Underwriters Laboratories (UL), and Factory Mutual (FM) that certify the technical specifications as required by NFPA 2001 in order to ensure the effective of clean agents in suppressing fires. Other fire extinguishing agents are available upon request.

Unique 5112 is a trademark of Unique's FK-5-1-12, Dodecafluoro-2-methylpentan-3-one. FK-5-1-12mmy2 is another widely used extinguishing clean agent. It is environmentally safe and best used in fire hazard areas containing A, B, & C classes of fire. It has been approved by US EPA and ISO for its safe characteristic and fire extinguishing effectiveness.

Clean Agents offered by Unique Fire is guaranteed to meet the minimum NFPA 2001 Requirement as follows.

TECHNICAL DATA	
CLEAN AGENT PROPERTIES	
IUPAC Name	1,1,1,2,2,4,5,5,5-Nonafluoro-4-(trifluoromethyl)-3-pentanone
ASHRAE Designation	FK-5-1-12
Synonym	Dodecafluoro-2-methylpentan-3-one
CAS Registry Number	756-13-8
Chemical Formula	CF ₃ CF ₂ CF ₂ CF ₂ CF ₃
Molecular Weight	316.04
Freezing Point	-162.4°F (-108°C)
Boiling Point at 760mmHg	49.2 °C / 120.6 °F
Critical Temperature	335.6°F (168.66°C)
Critical Density	39.91 lbm/ft ³ (639.1 kg/m ³)
Critical Pressure	270.44 psi (1,865 kPa)
Critical Volume	0.0251 f ³ /lbm (494.5 cc/mole)
Viscosity, Liquid at 77°F (25°C)	1.27 lb/ft-hr (0.524 cP)
Water Solubility at 70°F (21.1°C)	<0.001% by weight
PROPERTY REQUIREMENT	
Purity	99.0% (minimum)
Water Content (by weight)	0.001%
Non-Volatile Residue (g/100 ml)	0.05
Ozone Depletion Potential (ODP)	0
Global Warming Potential (GWP)	≤1
Atmospheric Lifetime (ATL)	0.014 years
US EPA SNAP (Yes/No)	Yes



All specifications and information indicated in this catalogue are subjected to change without prior notice.

UNIQUE FIRE INDUSTRY SDN BHD Co. No. 418731-U

Address:

No. 9, Jalan Anggerik Mokara 31/55, Kota Kemuning, Seksyen 31, 40460, Shah Alam, Selangor, Malaysia

Contact :

Tel : +603 5131 1226

E-mail : contactus@uniquefire.com

Website: www.uniquefire.com

SCAN ME



FK-5-1-12 CLEAN AGENT

Cylinders



INTRODUCTION

Unique 5112 Engineered Systems, as outlined in this manual, are those that are intended to be designed and installed to protect single or multiple hazards within the limitations tested by a recognized testing agency as stated in this manual ONLY. Authorities Having Jurisdiction (AHJ) should follow the information the Standard on Clean Agent Extinguishing Systems NFPA 2001. The equipment described in this manual is listed by Underwriters Laboratories, Inc. in accordance to the Standard for Halocarbon Clean Agent Extinguishing System Units (UL 2166). Our total flooding fire extinguishing systems are UL listed to utilize the Unique 5112 from Unique Fire under UL File EX 15295.

Cylinders

The Engineered Clean Agent System Cylinders are available in the following capacities: 20 lb, 35 lb, 70 lb, 100 lb, 150 lb, 250 lb, 375 lb 560 lb, 650 lb, 800 lb, 1000 lb and 1200 lb.

Cylinder Model

Unique 5112 Clean Agent cylinders are available in the following capacities :

TECHNICAL DATA							
Model No.	Cylinder Size	Max Fill at 75 lb/ft ³	Max Fill at 35 lb/ft ³	Dimension			Valve Size
				A	B	C	
UFI 70020-E*	20 lb	21 lb	11 lb	10.750"	13.632"	18.633"	1" Valve
UFI 70035-E*	35 lb	38 lb	18 lb*	10.750"	18.677"	23.678"	1" Valve
UFI 70070-E*	70 lb	76 lb	36 lb	10.750"	28.166"	33.167"	1" Valve
UFI 70100-F*	100 lb	108 lb	51lb	12.795"	26.709"	31.709"	1" Valve
UFI 70150-E*	150 lb	163 lb	77 lb	12.795"	37.343"	43.172"	1 1/2" Valve
UFI 70250-E*	250 lb	271 lb	127lb	16"	40.099"	45.928"	1 1/2" Valve
UFI 70375-E*	375 lb	406 lb	190 lb	16"	57.248"	65.351"	2 1/2" Valve
UFI 70560-E*	560 lb	601 lb	281 lb	20"	55.516"	63.619"	2 1/2" Valve
UFI 70650-E*	650 lb	712 lb	333 lb	20"	63.335"	71.438"	2 1/2" Valve
UFI 70650-F*	650 lb	712 lb	333 lb	20"	63.805"	72.569"	3" Valve
UFI 70800-E*	800 lb	900 lb	420 lb	30"	47.404"	58.941"	3" Valve
UFI 71000-E*	1000 lb	1112 lb	520 lb	30"	54.767"	66.303"	4" Valve
UFI 70800-F*	800 lb	900 lb	420 lb	30"	46.680"	55.438"	3" Valve
UFI 71000-F*	1000 lb	1112 lb	520 lb	30"	54.570"	62.801"	3" Valve
UFI 71200-E*	1200 lb	1297 lb	606 lb	30"	63.660"	73.500"	3" Valve



All specifications and information indicated in this catalogue are subjected to change without prior notice.

UNIQUE FIRE INDUSTRY SDN BHD Co. No. 418731-U

Address:

No. 9, Jalan Anggerik Mokara 31/55, Kota Kemuning, Seksyen 31, 40460, Shah Alam, Selangor, Malaysia

Contact :

Tel : +603 5131 1226

E-mail : contactus@uniquefire.com

Website: www.uniquefire.com

SCAN ME



FK-5-1-12 CLEAN AGENT

Cylinder Bracket



INTRODUCTION

The cylinder bracket is manufactured from galvanized steel band formed to the radius of the cylinder with flanges for bolting to the continuous slot metal framing channel of 12-gauge steel with corrosion resistant paint or galvanized. The channel must be supplied by the installer. The cylinder bracket must be secured to a surface that the bracket will withstand a load up to 5 times of the cylinder weight. This precaution is to have the bracket safely supports the weight of the cylinder and the reaction force of the Unique 5112 Clean Agent when discharge.

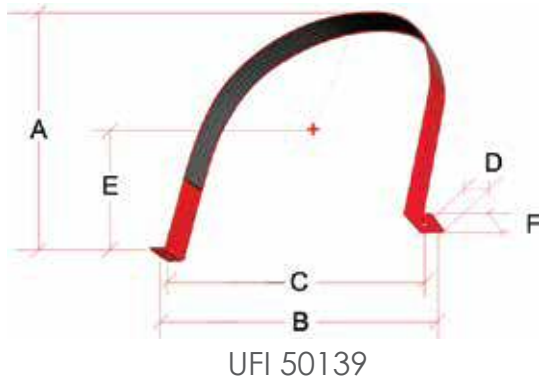

TECHNICAL DATA							
Part No.	Bracket Part	A	B	C	D	E	F
UFI 70020-E*	UFI 50139	11.000"	14.000"	12.600"	1.500"	5.600"	2.000"
UFI 70035-E*	UFI 50139	11.000"	14.000"	12.600"	1.500"	5.600"	2.000"
UFI 70070-E*	UFI 50139	11.000"	14.000"	12.600"	1.500"	5.600"	2.000"
UFI 70100-F*	UFI 60780	13.000"	16.050"	14.650"	1.650"	6.480"	2.000"
UFI 70150-E*	UFI 60780	13.000"	16.050"	14.650"	1.650"	6.480"	2.000"
UFI 70250-E*	UFI 60760	16.250"	19.200"	17.700"	1.500"	8.200"	2.000"
UFI 70375-E*	UFI 60760	16.250"	19.200"	17.700"	1.500"	8.200"	2.000"
UFI 70560-E*	UFI 60770	20.250"	23.200"	21.700"	1.500"	10.100"	2.000"
UFI 70650-E*	UFI 60770	20.250"	23.200"	21.700"	1.500"	10.100"	2.000"
UFI 70650-F*	UFI 60770	20.250"	23.200"	21.700"	1.500"	10.100"	2.000"
UFI 70800-E/F	UFI 60790	30.220"	35.200"	33.200"	2.500"	15.000"	2.000"
UFI 71000-E/F	UFI 60790	30.220"	35.200"	33.200"	2.500"	15.000"	2.000"
UFI 71200-E	UFI 60790	30.220"	35.200"	33.200"	2.500"	15.000"	2.000"
Part No.	Floor Bracket	A	B	C	D	E	F
UFI 70800-E/F	UFI 60792	5.900"	11.730"	10.350"	1.570"	2.000"	-
UFI 71000-E/F	UFI 60792	5.900"	11.730"	10.350"	1.570"	2.000"	-
UFI 71200-E	UFI 60792	5.900"	11.730"	10.350"	1.570"	2.000"	-



All specifications and information indicated in this catalogue are subjected to change without prior notice.

UNIQUE FIRE INDUSTRY SDN BHD Co. No. 418731-U

Address:

No. 9, Jalan Anggerik Mokara 31/55, Kota Kemuning, Seksyen 31, 40460, Shah Alam, Selangor, Malaysia

Contact :

Tel : +603 5131 1226

E-mail : contactus@uniquefire.com

Website: www.uniquefire.com

SCAN ME



FK-5-1-12 CLEAN AGENT

Cylinder Valve Assemblies



DESCRIPTION

The cylinder valves are back pressure type valves. A piston in the valve is equipped with a rubber seal that keeps FK-5-1-12 Clean Agent under pressure within the cylinder. A small hole in the piston of the valve allows cylinder pressure to be equalized on both sides of the piston. Since the area at the top of the piston is greater than the area at the bottom of the piston, the net force seals the piston against the valve discharge outlet. When the pressure on the top of the piston in the valve is released by an automatic or manual devices, the cylinder pressure acting against the bottom of the piston inside the valve will push the piston to slide upwards to its open position, allowing the pressurized agent inside the cylinder to discharge through the valve outlet.



1" Valve
Stainless Steel
UFI 90001-SS



3" Valve
Stainless Steel
UFI 3000-C



1.5" Valve
Stainless Steel
UFI 90002-SS



4" Valve
Stainless Steel
UFI 90004



2.5" Valve
Stainless Steel
UFI 90003-SS



All specifications and information indicated in this catalogue are subjected to change without prior notice.

UNIQUE FIRE INDUSTRY SDN BHD Co. No. 418731-U

Address:

No. 9, Jalan Anggerik Mokara 31/55, Kota Kemuning, Seksyen 31, 40460, Shah Alam, Selangor, Malaysia

Contact :

Tel : +603 5131 1226

E-mail : contactus@uniquefire.com

Website: www.uniquefire.com

SCAN ME



FK-5-1-12 CLEAN AGENT

Liquid Level Indicator



DESCRIPTION

The cylinder The Liquid Level Indicator is a simple, manually worked device, which gives a way to decide the Liquid Agent level in vertically mounted agent storage containers. Once the liquid level is resolved, it can then be changed over into the weight of Liquid Agent exhibit in the agent storage container.

OPERATION

A magnet furnished buoy moves with the fluid level along the unit stem. Level readout is gotten by essentially expelling the defensive cap and hauling out an aligned tape until attractive interlock with the buoy is felt. With the tape in this position, the perusing is acquired at the point where the tape rises up out of the unif lodging.

At the point when the fluid level is resolved, the reading is then referred to a chart in the Engineering Manual and the corresponding weight of Liquid Agent is determined. Accurate readings can be obtained over a +40°F to +90°F temperature range.



FEATURES

- Reduced maintenance time - weight in an agent storage container can be determined in a fraction of the time it would take to remove and weigh them.
- Continuous fire protection - use of the liquid level indicator does not require taking out the cylinder from the system, thus providing uninterrupted fire protection.
- Field installation capability - the indicator can easily be installed in the field using a single wrench as long as the container is empty and is equipped with a mounting boss.
- Compact - when not in use, the unit requires no more space than that required by the container.
- Flexibility - the flexible tape design allows the unit to be used in tight spaces that would otherwise hinder the use of a rigid type indicator "stick".
- Availability - units are available for all Unique containers from sizes of 150 lb. thru 1200 lb.

TECHNICAL DATA	
Part No.	Description
UFI 60020	Liquid Level Indicator for 150 LB & 250 LB Cylinders
UFI 60020-1	Liquid Level Indicator for 375LB & 560 LB Cylinders
UFI 60020-5	Liquid Level Indicator for 650 LB Cylinders
UFI 60020-4	Liquid Level Indicator for 800 LB Cylinders
UFI 60020-3	Liquid Level Indicator for 1000 LB Cylinders
UFI 60020-2	Liquid Level Indicator for 1200 LB Cylinders



All specifications and information indicated in this catalogue are subjected to change without prior notice.

UNIQUE FIRE INDUSTRY SDN BHD Co. No. 418731-U

Address:

No. 9, Jalan Anggerik Mokara 31/55, Kota Kemuning, Seksyen 31, 40460, Shah Alam, Selangor, Malaysia

Contact :

Tel : +603 5131 1226

E-mail : contactus@uniquefire.com

Website: www.uniquefire.com

SCAN ME



pg 70

FK-5-1-12 CLEAN AGENT

Flexible Hoses



DESCRIPTION

Flex hoses are utilized to interface the agent storage containers to the complex in numerous cylinders arrangement. Flex hoses are developed of high pressure driven elastic in the 1" and 1-1/2" sizes and stainless steel layered inward center with stainless steel interlaced in the 2-1/2" measure. All sizes are fitted with male NPT string on both finishes.

For the 650 lb, 800 lb and 1000 lb cylinders, the flex hose is 3" in measurement (Part # UFI 91230-C) and 18" long. The flex hose is fabricated from a stainless steel folded internal center with stainless steel interlaced. The flex hose has 3" Victaulic fittings on both closures.

For the 800 lb, 1000 lb and 1200 lb barrels, the flex hose is 4" in distance across (Part # UFI 91230) and 18" long. The flex hose is produced from a stainless steel layered internal center with stainless steel plaited. The flex hose has 4" Victaulic fittings on both ends.

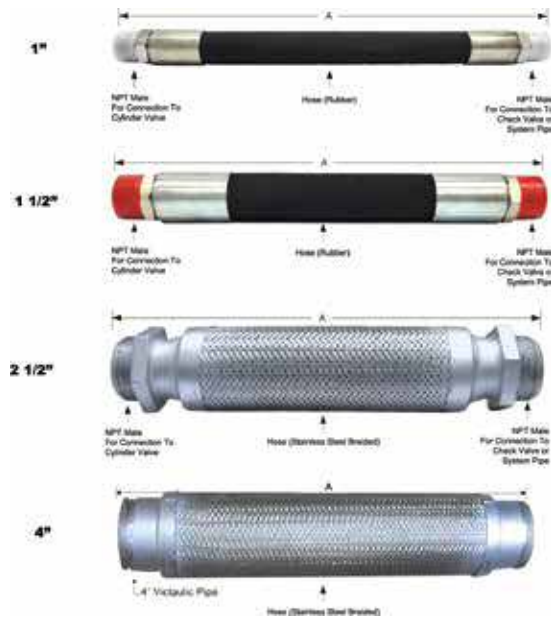

TECHNICAL DATA				
Part No.	Diameter	Description	A	Material
UFI 60255	1"	Flexible Hose	18"	Rubber
UFI 60256	1 1/2"	Flexible Hose	18"	Rubber
UFI 60257	2 1/2"	Flexible Hose	18"	Stainless Steel Braided
UFI 91230-C	3"	Flexible Hose	18"	Stainless Steel Braided
UFI 91231-A	3" x 6"	Flexible Hose	26"	Stainless Steel Braided / Brass
UFI 91230	4"	Flexible Hose and Check Valve Assembly	18"	Stainless Steel Braided
UFI 91231	4" x 6"	Flexible Hose and Check Valve Assembly	26"	Stainless Steel Braided / Brass



*Applicable for Unique 227 Fire Suppression System

UNIQUE FIRE INDUSTRY SDN BHD Co. No. 418731-U

Address:

No. 9, Jalan Anggerik Mokara 31/55, Kota Kemuning, Seksyen 31, 40460, Shah Alam, Selangor, Malaysia

Contact :

Tel : +603 5131 1226

E-mail : contactus@uniquefire.com

Website: www.uniquefire.com

SCAN ME



FK-5-1-12 CLEAN AGENT

Check Valves



DESCRIPTION

The Check Valves are utilized when at least two agent storage cylinders are manifolded together with one normal release funneling design. Their purpose is to keep the loss of agent if any of the agent storage cylinders are not associated with the complex at time of system release and to anticipate reverse of agent into different cylinders appended to the complex. All parts of the check valves are developed from metal for strength and protection against consumption. The metal to metal fixing range of the circle and seat is precisely lapped, giving a tight close off of both gas and fluid.



SHUTTLE VALVE

The brass Shuttle Valve is utilized to associate two chambers to a typical release pipe and nozzle(s). All strings are accessible with 1" or 1-1/2" NPT. The reason for having a reserve supply is that after the primary cylinder (main) is released, the second cylinder (reserve) can be physically exchanged by means of main/reserve change to reestablish putting out fires status.

The shuttle valve contains a shuttle check that shuts off the piping to the first cylinder (main) when discharge. At the point when the second cylinder is released, the shuttle check keeps the charge of the second cylinder into the first empty



TECHNICAL DATA	
Part No.	Description
UFI 50123	1" Shuttle Valve
UFI 60619	1 1/2" Shuttle Valve



All specifications and information indicated in this catalogue are subjected to change without prior notice.
UNIQUE FIRE INDUSTRY SDN BHD Co. No. 418731-U

Address:

No. 9, Jalan Anggerik Mokara 31/55, Kota Kemuning, Seksyen 31, 40460, Shah Alam, Selangor, Malaysia

Contact :

Tel : +603 5131 1226

E-mail : contactus@uniquefire.com

Website: www.uniquefire.com

SCAN ME



FK-5-1-12 CLEAN AGENT

Discharge Nozzle



DESCRIPTION

The function of the Discharge Nozzle, in a fire extinguishing system, is to distribute the Clean Agent in a uniform, pre-determined pattern and concentration. The nozzles are designed to complete the discharge of Clean Agent in 10 seconds or less when installed within the design limitations as stated in the installation instruction manual.

Discharge Nozzles are available in sizes of 1/2", 3/4", 1", 1-1/4", 1-1/2" and 2". Each discharge nozzle comes in two configurations: 180 and 360 degree distribution patterns.

Deflector plates are available as an option where sensitive ceiling tiles must be protected.

Discharge Nozzles are made with female pipe threads. The orifice size of the discharge nozzle is determined by the hydraulic flow calculations. All nozzles are rated for a maximum hazard height of 16 ft. If the hazard exceeds 16 ft. in height, a second tier of nozzles must be used.

Discharge nozzles are also available in Brass and Stainless Steel materials.



DISCHARGE NOZZLE SELECTION - SIDEWALL 180°

Typically to be installed adjacent to the center of the one wall of the enclosure. Its discharge path will be across the enclosure. At no time shall the area coverage be exceeded.

DISCHARGE NOZZLE SELECTION - CENTRAL 360°

Typically to be installed at the center of the enclosure. Its discharge path will be across the enclosure. At no time shall the area coverage be exceeded.

INSTALLATION

Please refer to Unique Installation, Maintenance & Service Technical Manual for Discharge Nozzles Area Coverage and Application Selections.

Part Number	Description	Part Number	Description
UFI 60704-2	1/2" (180°) Sidewall	UFI 60707-2	1 1/4" (180°) Sidewall
UFI 60704-3	1/2" (360°) Central	UFI 60707-3	1 1/4" (360°) Central
UFI 60705-2	3/4" (180°) Sidewall	UFI 60708-2	1 1/2" (180°) Sidewall
UFI 60705-3	3/4" (360°) Central	UFI 60708-3	1 1/2" (360°) Central
UFI 60706-2	1" (180°) Sidewall	UFI 60709-2	2" (180°) Sidewall
UFI 60706-3	1" (360°) Central	UFI 60709-3	2" (360°) Central

All specifications and information indicated in this catalogue are subjected to change without prior notice.

UNIQUE FIRE INDUSTRY SDN BHD Co. No. 418731-U

Address:

No. 9, Jalan Anggerik Mokara 31/55, Kota Kemuning, Seksyen 31, 40460, Shah Alam, Selangor, Malaysia

Contact :

Tel : +603 5131 1226

E-mail : contactus@uniquefire.com

Website: www.uniquefire.com

SCAN ME



pg 73

FK-5-1-12 CLEAN AGENT

Electronic Solenoid



DESCRIPTION

The Latching Solenoid Manual (UFI 50026-A) is connected to the removable fitting at the top of the cylinder valve. When activated, the latching solenoid opens the cylinder valve enabling the Clean Agent to release from the cylinder into the protected hazard. The latching solenoid is designed with an emergency local manual control (UFI 61003-2) release to manually activate the cylinder valve to release the extinguishing medium when needed. In order to reset the latching solenoid, the solenoid actuator pin is to be manually returned to the latched position.

SUPERVISION FUNCTIONS

- When connected into a System Release Control Panel: It has supervisory circuit to indicate if the latching solenoid has been removed physically from the valve.
- It has supervisory circuit to show fault if the connecting cables are compromised.

FEATURES

- High latching forces
- Fast response
- Manual Actuator Button
- Easy to manual reset
- Tested in compliance to UL864
- Equipped with safety pull-pin to prevent accidental manual activation of Clean Agent
- Stainless Max coating construction on body
- Stainless Steel 316L for lock-pin, plunger, swivel socket and manual actuator button

TECHNICAL DATA	
Activation Force	110 (N)
Holding Force	>100 (N)
Diagnostic Current	30 (mA)
Power Requirement	24 VDC \pm 10%
Current	0.5A @ 24 VDC
Electrical Connection	EN 175301-803 (ISO 4400)
	5 pin Switch / Pin 3 (+); Pin 2 (-)
Operating Temperature	- 4 to 131°F (-20 to 55°C)
Range	2.66 lbs (1.3 kg)
Weight	
Dimensions	1.77 in (45 mm)
Body Diameter	5.10 in (129.5 mm)



All specifications and information indicated in this catalogue are subjected to change without prior notice.

UNIQUE FIRE INDUSTRY SDN BHD Co. No. 418731-U

Address:

No. 9, Jalan Anggerik Mokara 31/55, Kota Kemuning, Seksyen 31, 40460, Shah Alam, Selangor, Malaysia

Contact :

Tel : +603 5131 1226

E-mail : contactus@uniquefire.com

Website: www.uniquefire.com

SCAN ME



FK-5-1-12 CLEAN AGENT

Pressure Supervisory Switch



DESCRIPTION

The Pressure Supervisory Switch is to monitor the pressure within the cylinder. It is attached to the port marked "p". If the cylinder to which it is attached leaks, its pressure drops to its release pressure or below, the switch contact will operate providing an indication on the Control panel that the cylinder has lost pressure.

ELECTRICAL RATING

120 VAC - 5.8FLA, 4.8LRA
240 VAC - 2.9FLA, 15LRA
24 VDC - 125VA Pilot Duty
28 VDC - 2 Amps

TEMPERATURE RANGE

Ambient: -20°F to + 150°F
Fluid
: -65°F to +275°F

SPEC C us

UFI501384

NC 240 110p

12-50-E

SPECIFICATION

1. Auto-Reset Pressure Switch (SPST)
2. Proof Pressure: 600 psig
3. Burst Pressure: 5000 psig
4. Electrical Ratings:
120/240 VAC - 375 VA
24 VAC - 125 VA
5. Cycle Life: 100,000 Minimum
6. Ambient Temperature: -30 to +70°C
7. Fluid Temperature: -54 to +135°C



TECHNICAL DATA

Model No.	Description	Operation
UFI 50138-7	500 psi M-10 (Brass/ Stainless Steel)	Normally Closed
UFI 50138-8	500 psi M-10 (Brass/ Stainless Steel)	Normally Open
UFI 50138-9	500 psi M-10 (Brass/ Stainless Steel)	Normally Closed
UFI 50138-10	500 psi M-10 (Brass/ Stainless Steel)	Normally Open

PRESSURE SUPERVISORY SWITCH GUARD

The Pressure Supervisory Switch Guard provides increased safety, flexibility and serviceability when used in the valve assembly. It is available in Stainless Steel. The Pressure Supervisory Switch Guard is used to prevent physical damage to the switch. The Pressure Supervisory Switch Guard incorporates a "no loss" connection which allows the pressure supervisory switch to be replaced easily and safely under pressure.



UFI 70215-2S



All specifications and information indicated in this catalogue are subjected to change without prior notice.

UNIQUE FIRE INDUSTRY SDN BHD Co. No. 418731-U

Address:

No. 9, Jalan Anggerik Mokara 31/55, Kota Kemuning, Seksyen 31, 40460, Shah Alam, Selangor, Malaysia

Contact :

Tel : +603 5131 1226

E-mail : contactus@uniquefire.com

Website: www.uniquefire.com

SCAN ME



pg 75

FK-5-1-12 CLEAN AGENT

PISTON ACTUATOR CONTROL HEAD-SLAVE



PISTON ACTUATOR CONTROL HEAD-SLAVE

- High quality brass construction
- Mounts directly on top of cylinder valves
- Self-venting

The Piston Actuator includes a pneumatically determined cylinder that depresses a Schrader check valve, along these lines venting the weight from the highest point of the cylinder in the cylinder valve, enabling the cylinder to slide upward and begin chamber release. The pneumatic weight required to work the Piston Actuator is acquired from the "M" port of a barrel, which is assigned as "Master" chamber that is either mechanically as well as electrically incited. Different barrels outfitted with Piston Actuators can be initiated from one ace chamber utilizing 1/4" copper tubing or 1/4" metal flex hose. The Piston Actuator mounts specifically to a top plug adapter, which is situated on top of the cylinder valve.

Pressure supplied by Port M
of Master Cylinder Valve



UFI 61041

TECHNICAL DATA	
Thread for Piston Actuator	Available in 1", 1 1/2", 2 1/2"
Control Head - Slave	3", 4" sizes
	1/4" Copper Tubing or
Thread for Pilot Connection	1/4" metal Flex Hose
Minimum Pilot Pressure	3.45 Bar (50 PSI)
Maximum Pilot Pressure	34.5 Bar (500 PSI)
Material	Available in Brass or Stainless Steel

Note: 1/4" Metal Flex Hose are available as follows:

TECHNICAL DATA	
Part No.	Description
UFI 50192-3	12" Length
UFI 50192	20" Length
UFI 50192-1	24" Length
UFI 50192-2	36" Length



All specifications and information indicated in this catalogue are subjected to change without prior notice.

UNIQUE FIRE INDUSTRY SDN BHD Co. No. 418731-U

Address:

No. 9, Jalan Anggerik Mokara 31/55, Kota Kemuning, Seksyen 31, 40460, Shah Alam, Selangor, Malaysia

Contact :

Tel : +603 5131 1226

E-mail : contactus@uniquefire.com

Website: www.uniquefire.com

SCAN ME



FK-5-1-12 CLEAN AGENT

Pressure Gauges and Guard



DESCRIPTION

Pressure Gauges indicate the operating pressure of the gas contained in a pressure vessel. The pressure gauge can be directly mounted into the Stainless Steel Cylinder Valve. These pressure gauges are known for being sturdy, durable and resistant to damage.



TECHNICAL DATA			
Part No.	Operating Pressure	Operating System	Thread
UFI 70282-M2	500 PSI	FK-5-1-12	M 10
UFI 70282-N	500 PSI	FK-5-1-12	1/8" NPT

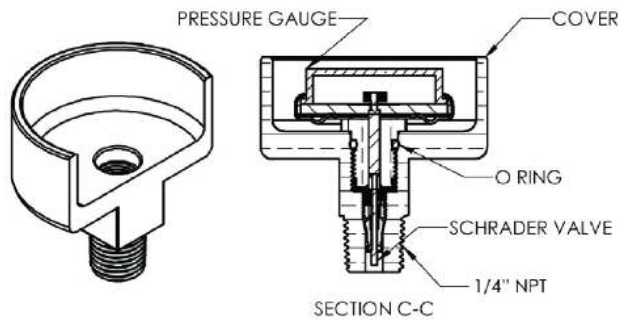

PRESSURE GAUGE GUARD

This protects the gauge from force which can cause breakage. The Schrader Valve attached on the pressure gauge guard makes maintenance simple by allowing the removal of either gauge without the need of releasing the pressure.

Features

- Protect gauges from corrosive process media.
- Helps reduce instrument failures and system downtime.
- Assures long life and accurate results of the pressure gauge



All specifications and information indicated in this catalogue are subjected to change without prior notice.

UNIQUE FIRE INDUSTRY SDN BHD Co. No. 418731-U

Address:

No. 9, Jalan Anggerik Mokara 31/55, Kota Kemuning, Seksyen 31, 40460, Shah Alam, Selangor, Malaysia

Contact :

Tel : +603 5131 1226

E-mail : contactus@uniquefire.com

Website: www.uniquefire.com

SCAN ME

