

INGAL GUARDRAIL

WEBFORGE

A valmont COMPANY



NJB (Type 5)

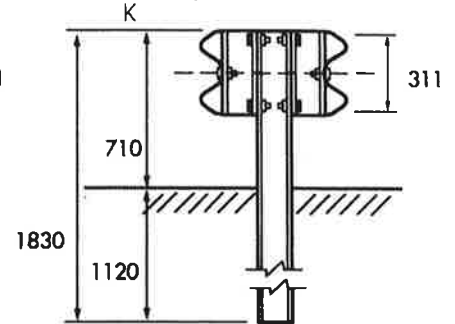
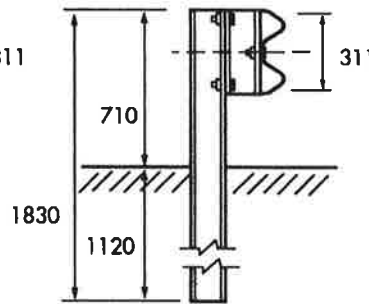
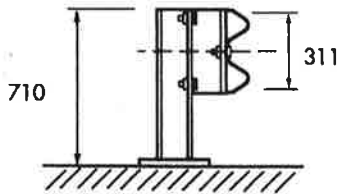
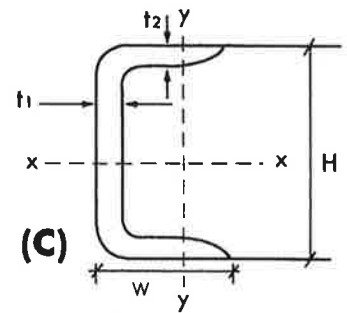
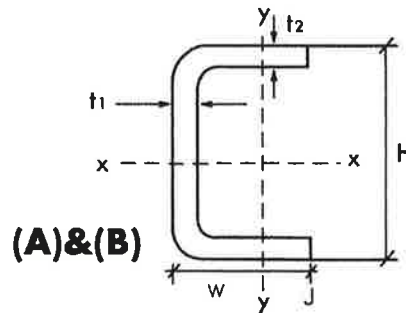

INGAL GUARDRAIL POST

TYPE	H x w x t1 x t2(mm)	Unit Weight (kg/m)	Section Area (cm ²)	Moment of Inertia		Section Modulus	
				I _x (cm ⁴)	I _y (cm ⁴)	S _x (cm ³)	S _y (cm ³)
A	C178 x 76 x 6 x 6	14.3	19.08	903.5	102.5	101.5	52.0
B	C150 x 76 x 6 x 6	13.2	17.50	610.0	98.0	80.0	45.3
C	C125 x 65 x 6 x 6	13.4	17.11	425	65.5	68.0	14.4

FISH TAIL TERMINAL UNIT (TYPE 1)

